



## COUNTERTOP WATER PURIFICATION SYSTEM



### Owners Manual WFL Model 122

Water for Life Corporation 29 Scudder Road, Newtown, CT 06470 USA  
203-270-1522 877-LIFE-H20 (877-5433-420) Fax 203-426-1929

## **Congratulations!**

You have purchased the finest countertop water purification system on the market today. You have taken a major step in improving the quality of your drinking water and in contributing to your family's health.

The WFL water purification system is a uniquely designed multi-stage system that provides the user with pure water right from the tap and is easily installed.

WFL provides clean, clear, better-tasting water while eliminating the potential bacteriological problems associated with ordinary filtration systems.

This process represents the best technology available to remove unwanted impurities yet retain good taste.

According to a study conducted by the United Nations, polluted water is one of the major causes of infectious diseases. The new Water for Life purification system protects the quality of your drinking water.

Water for Life utilizes ultraviolet sterilization because it has proven to be the most effective method to kill bacteria and viruses in your drinking water. The UV energy far exceeds other countertop units, and is combined with two stages of filtration.

## Table of Contents

Important Safeguards	3
How It Works	3
Installation	4
Ultraviolet Lamp and Filter Installation	5
Faucet Connection	5
Initial System Operation	5
Replacing The UV Lamp and Filters	6
System Maintenance	7
Specifications	7
Warranty	8

### Important Safeguards – please read carefully

- ❖ The Water for Life (WFL) unit is not intended to, nor does it soften or remove all minerals from water, **and does not replace distilled water for use in steam irons.**
- ❖ The WFL unit is intended for indoor installation and use only.
- ❖ Replace the filter cartridges at least twice each year.

#### **WARNING:**

**Unplug the unit before servicing.** The ultraviolet lamp uses in excess of 70 volts, which could represent a shock hazard.

**Never look at the ultraviolet lamp while it is on.** Exposure could cause serious eye damage up to blindness.

### **How it Works**

The unfiltered water enters the system through a pre-filter, where the impurities such as rust and sediment are trapped. Then the water passes through the sterilization chamber inside the pre-filter housing, where microbiological organisms are exposed to UV light, destroying the DNA. This prevents bacteria buildup in the carbon filter, which follows. The activated carbon filter is specifically designed to remove chlorine and other undesirable tastes and odors. Leaving the second filter chamber, the water goes directly to the faucet. The water drawn is clear, clean and pleasant tasting. You will be amazed at how much better foods cooked with purified water will taste and how delicious beverages like tea and coffee can be.

# Installation

## Parts

All installation parts and components are included with the system. Please take a few moments to become familiar with all of the parts before proceeding with the installation.

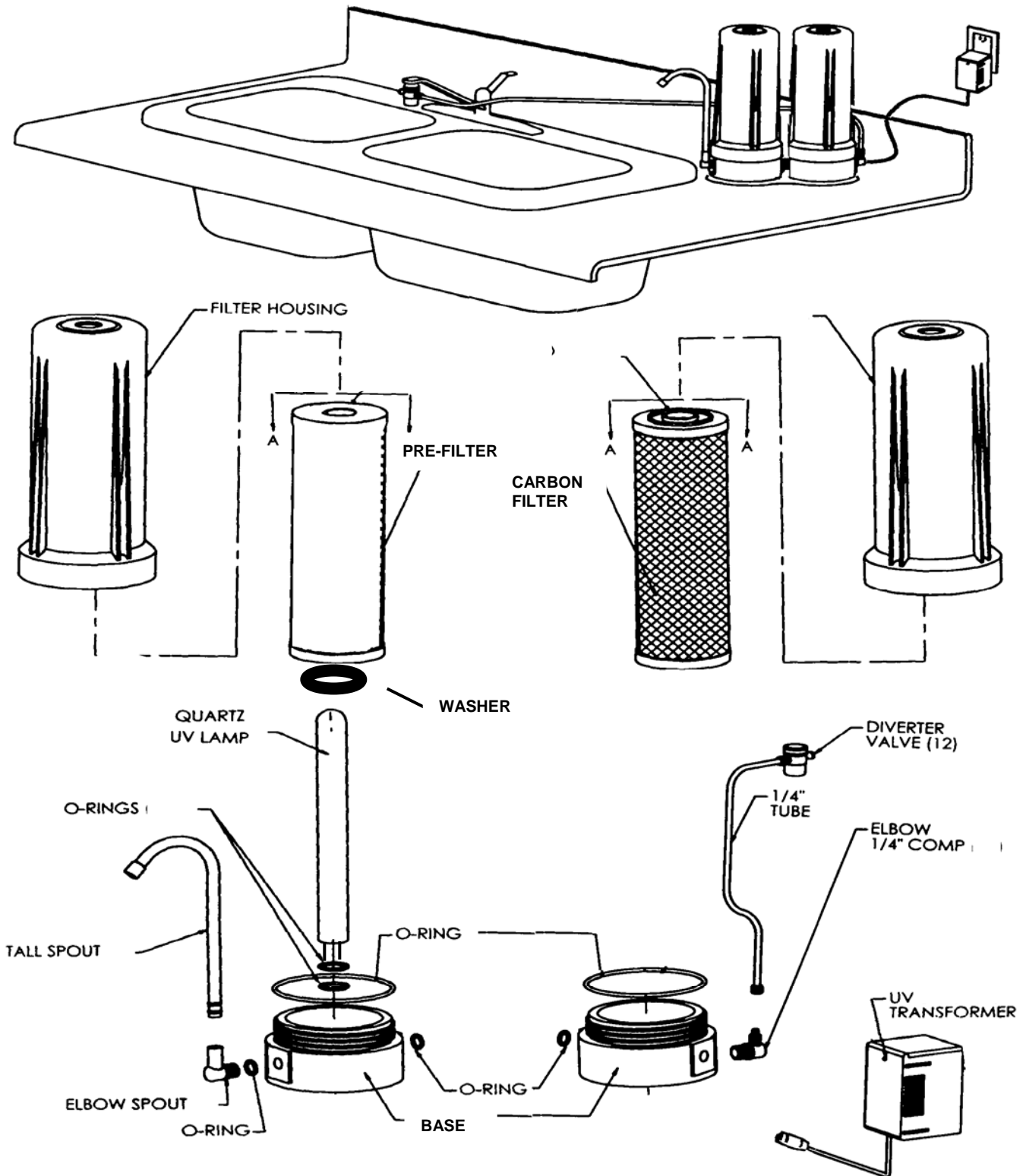

## **Installation**

---

### **1. Ultraviolet Lamp and Filter Installation**

- ❖ You must install the new lamp before continuing. In many instances, the unit may be shipped with the lamp and filters already installed. To verify, unscrew the housing attached to the diverter valve hose. To install, refer to the instructions “Replacing the UV Lamp and Filters” on page 5. Replace the housing.
- ❖ Plug the wall adapter unit into the electrical outlet and into the unit. This will activate the Ultraviolet lamp. Once the system has been turned on, it should be left on continuously, so that no recontamination can occur.

### **2. Faucet Connection**

- ❖ The unit comes with a diverter valve that in most cases will screw directly onto the sink faucet. In the event of an unusual configuration, you may obtain the necessary adapter from either your local plumbing supply store or by contacting WFL directly.

### **3. Initial System Operation**

- A. Turn ON the **cold** water and pull handle on the diverter valve to fill the purifier.
- B. Allow a minute for the water to fill the system.
- C. Turn the system upside down and hold in that position until water again flows through the purifier’s spigot.
- D. Turn off the water. Return the unit to its upright position.
- E. System is now ready for use.

**NOTE: Use cold water only for normal system operation.**

## **Replacing the UV Lamp and Filters**

---

### **THE ULTRAVIOLET LAMP SHOULD BE REPLACED ANNUALLY.**

Over time, the intensity of the ultraviolet lamp, which is rated for 9000 hours, will diminish until it is not satisfactory to destroy the organisms in the water. When the lamp is a year old, it should be replaced. Do not wait for the safety indicator at the bottom to turn from green to red to change the lamp. If the indicator is red and the horn sounds, the UV lamp is not working, and the microorganisms in the water will no longer be destroyed. **If this occurs, the lamp should be replaced immediately!!**

### **THE FILTERS SHOULD BE REPLACED AT LEAST SEMIANNUALLY.**

## Replacing the UV Lamp and Filters

---

### 1. Disassembly

To ensure proper operation of the system, the *pre-filter cartridge* should be replaced at least twice a year or when the flow becomes significantly reduced.

1. Disconnect the unit from the electrical outlet **BEFORE** replacing the filter cartridges.
2. Turn **OFF** the source water to the unit.
3. Turn system upside down over the sink. Unscrew the *filter housings* from the *filter cap*, by turning the *filter housing* counterclockwise, using the supplied filter wrench. Remove the old *filter cartridges* and discard.
4. It is a good idea to rinse out the filter housings and fill about 1/3 with water. Add a few drops of bleach and scrub thoroughly with a brush or sponge. Rinse thoroughly afterwards.
5. The lamp used in this system looks similar to a fluorescent lamp, and includes a protective quartz sleeve. The pins push straight into an internal pin socket. **DO NOT TWIST THE LAMP**. Remove the old lamp by pulling straight out.

### 2. Reassembly

1. Place a thin coating of petroleum jelly on the 2 O-rings and place them in the shoulder of the lamp pin socket. Also coat the side of the lamp from the pin end about ½ inch up the side. Insert the new lamp (pin end **FIRST**) by holding the end opposite the pins, then sliding the lamp **STRAIGHT** through the 2 O-rings and gently into the system until it is seated in the internal socket. A guide is located at the internal socket to assure proper and easy alignment. Once the lamp has been guided into the connector, push straight in (**DO NOT TWIST**) to properly seat it in the socket.

NOTE: When you remove the lamp from its package, handle it carefully by the tips or use latex gloves. If you touch the side of the bulb, oil from your skin will interfere with the transmissibility of the ultraviolet light. Clean the lamp with a soft cloth and rubbing alcohol should this occur.

2. Verify the O-ring of each *filter housing* is in place. The O-rings may be lubricated with petroleum jelly if necessary.
3. Remove the outer plastic wrap from the new *filter cartridge(s)*.
4. Place the new *filter cartridge(s)* into the *filter housings* and seat securely. The prefilter is on the inlet housing containing the UV lamp. **This filter must be put in with the washer down on the base of the housing**. The 5-micron carbon cartridge is placed in the other housing.
5. Screw the *filter housing(s)* onto their correct *filter cap(s)* and tighten securely.
6. Follow Initial System Operation start-up procedure (see page 5)

## **System Maintenance**

---

Under normal operation, the system requires minimal maintenance. Usually, the only maintenance requirement is of changing the pre-filter cartridge every three to six months, the filter cartridges every six months to one year and the UV lamp once a year.

Individual usage and inlet water quality may dictate more frequent filter replacement. The filters should be replaced immediately if your water flow becomes restricted, or if bad taste and odors return, even if six months have not yet elapsed.

### **Replacement Parts**

To ensure optimal performance from your Water for Life system and to protect your warranty, use only genuine Water for Life filters and lamps available from your Water for Life dealer.

**Ultraviolet Lamp:**

UV Lamp: input power - 14 watts

**P/N 1200029**

**Pre-filter Cartridge (spun polypropylene)**

5-micron

**P/N 1200032**

**Filter Cartridge 2 (activated carbon for general use)**

**P/N 1200010**

or:

**Filter Cartridge 2 (for lead removal)**

**P/N 1200034**

**Filter Cartridge 2 (for iron removal)**

**P/N 1200035**

### **Specifications**

**Flow Rate:**

3/4 GPM (4 LPM)

**Power Requirements:**

Input: 120v 60Hz or 240v 50Hz  
15 watts operating

**Operating Pressure:**

20 - 80 psi

**Overall Dimensions:**

10" W x 12" H x 6" D

## Warranty

---

### THIS WARRANTY COVERS THE WATER FOR LIFE RESIDENTIAL PRODUCT LINE

**Purifier unit:** The Water for Life purifier unit is warranted for a period of one (1) year from the date of purchase against defects in material and workmanship. This warranty covers original components installed by Water for Life at our factory. Expendable items (bulbs and filters) are not covered under this warranty.

This warranty is void if equipment is not installed and operated according to the instructions as listed in the Owners Manual. It does not apply to damage caused by abuse, accident, neglect, freezing, fire, or other abnormal conditions beyond the company's control. This warranty is void on any part from which the original manufacturing date code decal has been removed or made illegible. This warranty requires the use of Water for Life authorized replacement parts. All models must be operated and maintained in accordance with this Owners Manual.

This warranty shall be void if the influent water temperature exceeds 110 degrees F. or goes below freezing. This purifier is intended for use inside the home and with cold water only.

All defective parts must be returned to Water for Life, Inc. for inspection and repair or replacement. Contact factory for a **Return Materials Authorization Number** prior to shipment. Water for Life will inspect, test and determine cause of defective component parts. Water for Life will have final determination as to which component parts are replacement of total units; and the cost of labor, new components, handling and packaging. Defective parts must be sent prepaid freight. Water for Life, Inc. will not be liable for any labor charges other than factory repairs. Incidental or consequential damages are not covered by this warranty.

All claims must be submitted in writing to your ultraviolet equipment supplier within thirty (30) days from the discovery of the defect. Thereafter, your ultraviolet equipment supplier will correct defective parts and/or workmanship within sixty (60) days from the time of receiving this notice.

**This warranty is valid once the customer completes the applicable Warranty Form. These forms must be sent back to the pertinent distribution center to keep on file.**



29 Scudder Road, Newtown, CT 06470 USA

203-270-1522 877-LIFE-H20 (877-5433-420)

Fax 203-426-1929