



Water for Life Corporation

Safe Water Distribution System

Overview

The WFL Safe Water Distribution System is designed to handle a wide variety of water situations, including various water sources, expansion to serve 2000 or more people, using supplemental commercial power on cloudy days and using cloudy or contaminated water.

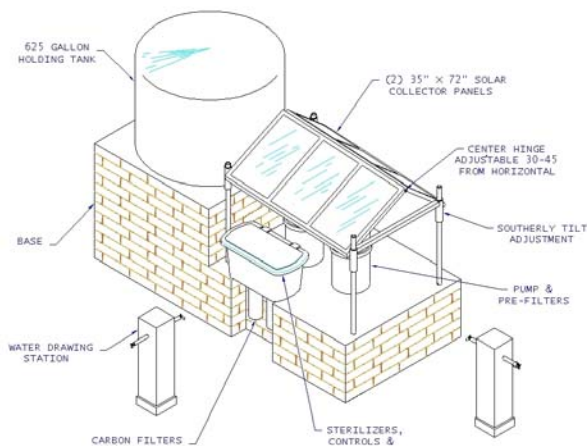

platform with filtration

It is designed with the following capabilities:

- ❖ Capable of pumping 3 gpm continuously for 12 hours per day (standard pump).
- ❖ Capable of running on solar energy alone
- ❖ Capable of pumping at least 75 feet vertical lift (standard pump)
- ❖ Option for using supplemental line power to extend operation to nighttime and rainy days
- ❖ Capable of removing at least 99% sand and rust from water
- ❖ Capable of removing at least 99% bacteria, cyst, amoebae from water
- ❖ Capable of removing at least 99% DDT, lead, or heavy metals from water (using carbon filters)
- ❖ Capable of operation 8 hours per day minimum on sunny days and 4 hours equivalent on rainy days (solar-only version)
- ❖ Capable of having pre-filters cleaned and backwashed a minimum of 100 times before replacing
- ❖ Replacement of pre-filters and UV lamp, 1 year minimum

- ❖ Replacement of carbon filters (if needed), 6 months
- ❖ Replacement of pump diaphragm, 3 years minimum
- ❖ Design lifetime of rest of system, 15 years
- ❖ Capable of being installed by technical personnel in country
- ❖ Capable of being maintained by a trained person having a secondary school degree and mechanical aptitude
- ❖ Capable of having maintenance and preventive maintenance done primarily at night with no more than 1 day down time.

Equipment Supplied

Basic system (artesian well, hillside location with unit 50 feet below source, reliable commercial power available, 500-1000 people served)

- ❖ Purification system with (2) WFL UV 200-5 sterilizers
- ❖ 2 pre-filters (Sta-Rite Model PLM150)
- ❖ 600 gallon minimum storage tank (user choice)
- ❖ 100 feet water hose to pump, 100 feet water hose to stanchions.



Sterilizer box with optional carbon filters



Pre-filters showing cartridge and valves

Standard Pump Option (source: stream not on a hill, or pump at depth less than 80 feet):

- ❖ Submersible pump (Kyocera Model 6-30)

Deep well Pump Option (source: pump at depth between 80 and 200 feet):

- ❖ Submersible pump (Kyocera Model 8-60)

Solar power (can be used in conjunction with AC power option to tap into unreliable commercial power):

- ❖ (6) Kyocera Model KC-50 solar panels (shallow well option)
- ❖ (10) Kyocera Model KC-50 solar panels (deep well option)



Installation

Preparing the Site

The site is chosen with the following considerations in mind:

- ❖ If an artesian spring is available on a hillside, and the system can be located at least 50 vertical feet below the source, then no pump will be needed.
- ❖ The basic system comes with 100 feet of pipe. Additional pipe will be needed if the source is further away.

Building the Foundation Structure

- ❖ Follow the dimensions of the print (Figure A1). The system should rest on a cement pad. Use cement block and standard building techniques employing reinforcing bar to strengthen the structure. Fill the structure with rock and stone, and cap with cement.

Building the Faucet Support

- ❖ Faucet Stanchions permit faucet locations to be spread out over several hundred meters. Two $\frac{3}{4}$ inch pipes are run from the purifier/control box underground in opposite directions from the system to the first set of stanchion locations. Two spigots are placed on each stanchion. The second set is tapped into the first set and extends further out from the system location in each direction. Up to 8 faucets can be connected to one system.
- ❖ If the unit is put into a courtyard, the spigots may be put into a wall for security. Access is from the outside of the wall. In this instance, 4 faucets are recommended; two connected to each $\frac{3}{4}$ inch pipe coming from the sterilizer/control box.
- ❖ If the secure tower system is built, then 8 faucets are connected to two manifolds supplied with the system, and spaced around the tower.

Installing Pump in Well Location

The well needs to be capped at least 1 foot above the ground, to prevent contamination by runoff. If the well casing diameter is at least 5 inches, the Kyocera SD-30 pump can be used. If the diameter is 6 inches or larger, and the lowest water level is at least 10 feet from the bottom, then a sand shroud should be used with the pump. Refer to the Kyocera instruction manual for detailed installation instructions.

Installing Pump in Stream Location

If a well is not available, a year-round stream or pond can be used. Choose a quiet location away from the rapidly moving area. One method is to construct an inlet chamber using a 55 gallon drum. Place the drum into the stream $\frac{3}{4}$ covered with water with the bottom plug open (additional holes in the bottom are recommended). Fill the bottom $\frac{1}{4}$ with gravel and the next $\frac{1}{4}$ with washed sand. The submersible pump should be suspended about 1 foot above the sand level.

Electricity option

The unit will accept 110V 60 Hz or 220V 50 Hz. A switched line must be used, fused at 15 amp. NEMA-4 weatherproof boxes are available that contain both the switch and fuse capabilities. A weatherproof power cord or extension cord having at least 15 amp capability may be used. The sterilizer/control box contains a weatherproof electrical box that houses the power transformer and a circuit breaker to protect the equipment.

Installing Pre-Filters on Location

The pre-filters come pre assembled on a shipping skid. The skid should be placed on the foundation where the filters will finally rest, and then removing the bolts, the skid should be gently removed. The filters should then be bolted to the foundation.

Connect water pipes to pump and drain locations. Connections are labeled, but check with block diagram (appendix xxx) to verify connections.

Placing Purifier Unit on Location

Bolt sterilizer/control box into place

Install carbon filters into housings (if applicable).

Connect water lines to pre-filters.

Connect electrical lines. Wires are numbered on the terminal block inside the sterilizer/control box.

Placing Tank on Location

Bolt into place

Place float switch in tank according to instructions supplied.

Connect float switch electrical line to Kyocera pump control unit according to numbered wires.

Placing Solar Panels on Location

Solar panels are pre-assembled and pre-wired at the factory.

Bolt in place

Adjust for best solar angle

The solar panel poles come set-up for the correct latitude. There are 3 adjustment positions. The center position is correct in the spring and fall, and has about 10% reduction of power in summer and winter. If this is adequate, then the system can stay in this position. Otherwise, it will have to be adjusted for each season.

Connect electrically to sterilizer/control box. Wires are numbered at the terminal strip for easy identification.

Operation

Check for electrical operation. The switch to operate the sterilizers is located inside the sterilizer control box. Remove the cover and turn on the switch. Verify that the sterilizer lamps are on (handles glow) and that neither lamp failure warning horn sounds.

Switch on the pump inside the cover of the pump controller. Verify that water flows.

The pre-filters must be coated with cellulose. Filter 1 is coated first. Close all valves. Fill the standpipe with cellulite and replace cap.

Valve positions: Open valves V1 and V5.

Filter 2 is coated next. Switch off the pump (switch is located inside cover of pump control box). Fill the standpipe with cellulose. Close all valves. Open valves V2 and V5. After 1 minute of operation, open valve V1 for normal operation.

Check system for leaks. Tighten any hose-clamps that have small drips.

Maintenance

The pre-filters need to be periodically cleaned. There are 3 levels of cleaning possible for each of the 2 filters. Each situation is different, and the time interval between these cleanings will be determined by experience.

- ❖ Purging – The bottom ¼ of the filter housing is void, allowing sand and dirt to accumulate. Purging consists of opening the drain valves (V4 and V7) for 1 minute while the pump is in operation, allowing water to wash away these impurities. Close valves V4 and V7 to resume normal operation.

Purging pre-filters:

Valve positions: Open V4 and V7 with pump operating and V5 open.

Resuming operation:

Valve positions: Close V4 and V7.

- ❖ Backwashing – Consists of reversing the flow of water through the filter, thereby pushing sand and dirt imbedded in the filter cartridge out from the inside. Closing the valve to the purifier and opening the drain valve, then reversing the flow through the filter for 2 minutes for each filter by opening the bypass valves will accomplish Backwashing.

Backwashing pre-filter 1

Valve positions: Close all valves. Open valves V3 and V7.

Backwashing pre-filter 2

Valve positions: Close all valves. Open valves V3 and V4.

Resuming operation: After the pre-filters are backwashed, they must be coated. Follow the procedure outlined in the OPERATION section.

- ❖ Cleaning – The filter can be removed for cleaning. Using the pump connected to a spray hose, the dirt is power-washed off of the pleated filter. Use the high-pressure nozzle setting of a garden hose. Start at the top and slowly work down, spraying well inside the pleats. This is a very expensive cartridge, and it is important to clean it as well as possible without damaging it.

Turn pump off.

Valve positions: Close all valves.

Remove top of filter 1 and 2. Remove filter cartridges.

When the pre-filters are cleaned, they must be coated. Follow the procedure outlined in the OPERATION section.

Replacement

We recommend replacement of the ultraviolet lamps once a year. Otherwise UV output declines by about 20% each year for the first few years, causing the unit to be less effective over time. 3 sets of lamps are provided with the system for operation for 3 years minimum.

Pre-filter replacement is needed when the filters become too plugged to be cleaned adequately by the 3 methods described in MAINTENANCE or develop a hole. Conditions vary greatly, but the filters should last at least 1 year. 3 sets of filters are provided with the system for operation for 3 years minimum.

Carbon filters (if used) should be replaced when water testing indicates they are no longer being effective at removing the contaminants they are used for. Conditions vary greatly, but the filters should last at least 6 months. They cannot be cleaned. 6 sets of filters supplied with the unit should last 3 years minimum.

For replacement filters and UV lamps contact:

Water for Life Corporation Tel: (203) 270-1522

255 S. Main, PO Box 500 Fax: (203) 426-1929

Netwown, CT 06470 USA E-mail: sales@waterforlifecorp.com.

Iron Removal Filter Pool System

A low-technology filter that removes both iron and arsenic from water has been built and tested by research scientists at New Mexico Tech University. This adaptation of the filter holds great promise based on their results in Ghana, and is still in development phase.

The filter consists of graded laterite, a paving stone of iron oxide that is incorporated into a single chamber made of concrete bricks and mortar.

Construct the filter as follows:

- ❖ We recommend setting the base at a depth of 1-2 feet in the earth. The dimensions of the filter are 1m wide x 3 m length x 1 m height. Use standard construction techniques, ensuring that the tank is well sealed to prevent leakage.
- ❖ The inlet of the filter is a 5 gallon bucket located at one end of the tank. This could be positioned underneath the spigot of a hand-operated pump, at the outlet of a submersible pump, or both.
- ❖ The filter outlet is a 55 gallon drum (or equivalent) located at the opposite end of the tank. Drill 50-100 holes $\frac{1}{4}$ inch diameter along the bottom, $\frac{1}{2}$ the diameter of the drum. Place drum in pool with holes facing the back and sides of the pool.
- ❖ Use 1 cm laterite stones for the areas nearest the drum. Fill to near the rim. The same stones or smaller can be used throughout the tank.
- ❖ The 5 gallon bucket should be set in so that the rim is just higher than the laterite, near the top of the tank. Ensure that stones do not fall in.

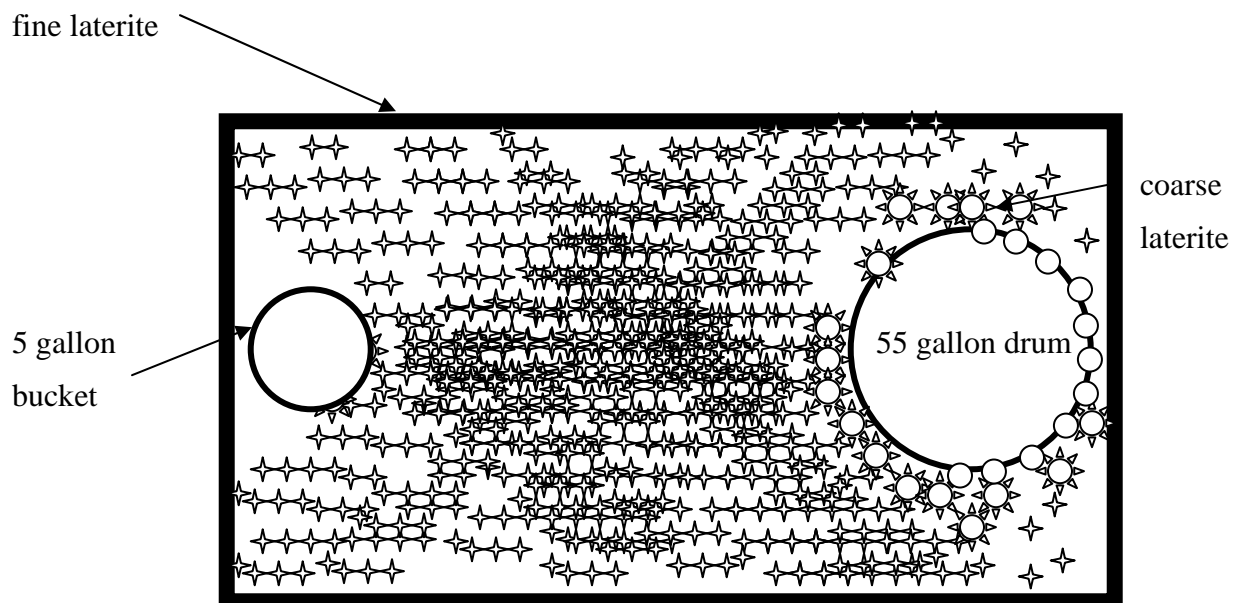

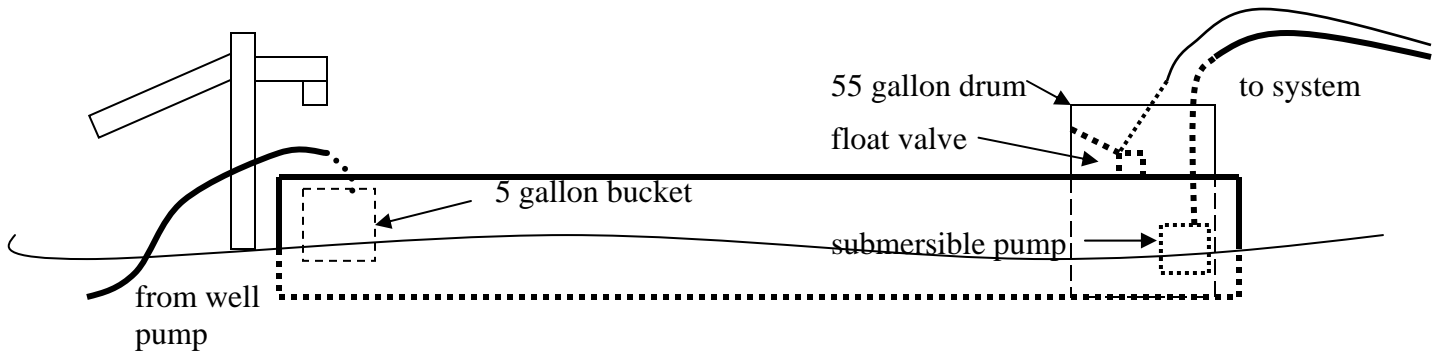

We recommend three reinforced concrete covers for the filter. Each cover should be approx. 1 meter square, large enough to completely span the tank. The bucket end cover will need a large enough hole for water to enter without spilling. The drum end cover needs to be made with a circular slot large enough to slip over the drum. All three covers should have handles made of reinforcing bar to enable lifting for maintenance.

Replacement of the laterite

The estimated lifetime of the laterite material is one to two years. The laterite can be shoveled out and used for other purposes such as roads, etc. When replacing the laterite, we recommend resurfacing the inside of the tank to ensure that it remains leakproof.

Iron Removal Filter Pool System

A low-technology filter that removes both iron and arsenic from water has been built and tested by research scientists at New Mexico Tech University (see Appendix). This adaptation of the filter holds great promise based on their results in Ghana, and is still in development phase.

The filter consists of graded laterite, a paving stone of iron oxide that is incorporated into an above ground swimming pool as a container.

Construct the filter as follows:

- ❖ Follow manufacturer's setup instructions for pool erection. We recommend setting the pool to a depth of 1-2 feet in the earth.
- ❖ The inlet of the filter is a 5 gallon bucket located at one end of the pool. This could be positioned underneath the spigot of a hand-operated pump, at the outlet of a submersible pump, or both.
- ❖ The filter outlet is a 55 gallon drum (or equivalent) located at the opposite end of the pool. Drill 50-100 holes $\frac{1}{4}$ inch diameter along the bottom, $\frac{1}{2}$ the diameter of the drum. Place drum in pool with holes facing the back and sides of the pool.
- ❖ Use 1-3 cm laterite stones for the areas nearest the 5 gallon bucket. Fill to near the rim. Use the same stones on the drum side, filling to the top of the pool.
- ❖ Use 1-2 mm stones to fill the remainder of the pool.

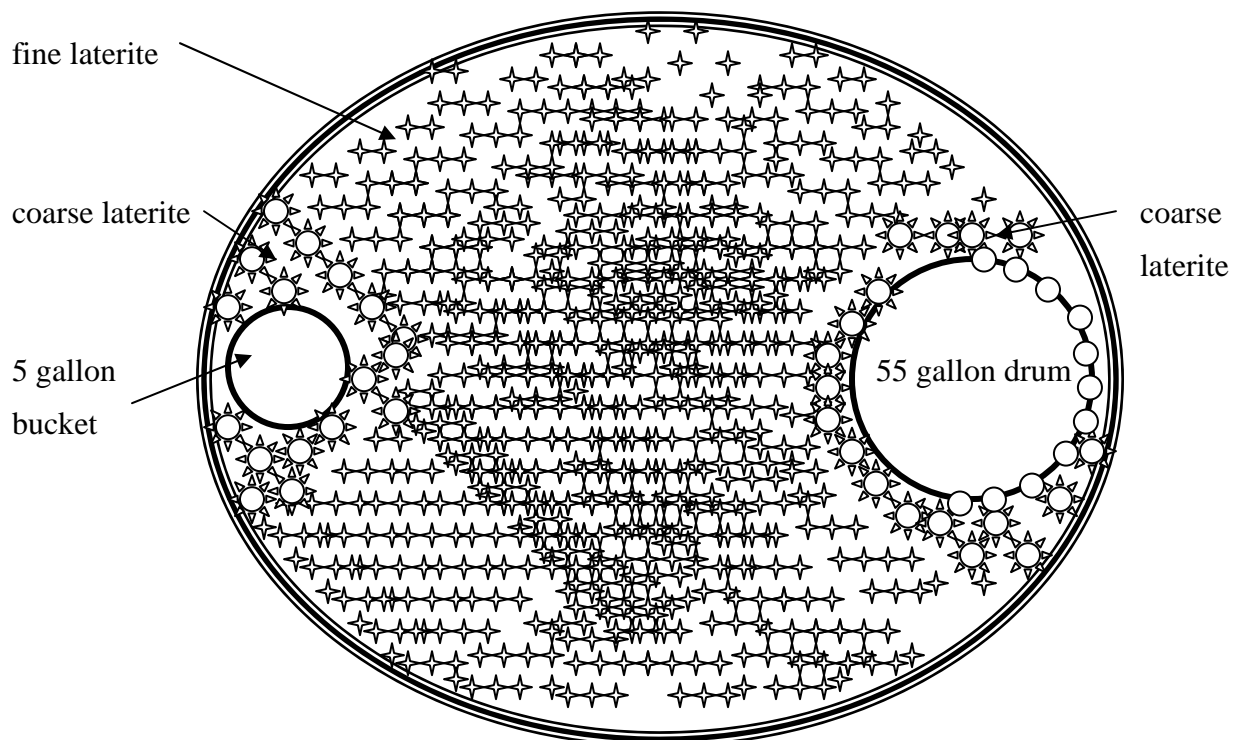

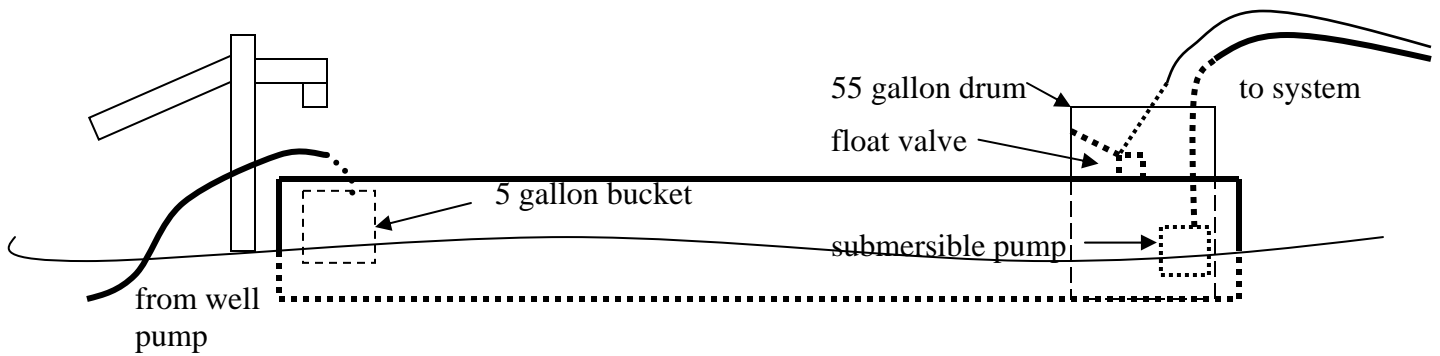

Placing the 5 gallon bucket in the pool, the top should be below the pool rim. The stones around the bucket should be lower than the top, so that they don't fall in.

Cover the pool following manufacturer's instructions.

Replacement of the laterite

The estimated lifetime of the laterite material is one year. The laterite is best removed using buckets. In any case, care should be taken not to damage or puncture the pool canvas. A repair kit is provided should small punctures occur.

The estimated pool lifetime is 3 years. This can be longer if care is taken in laterite replacement.

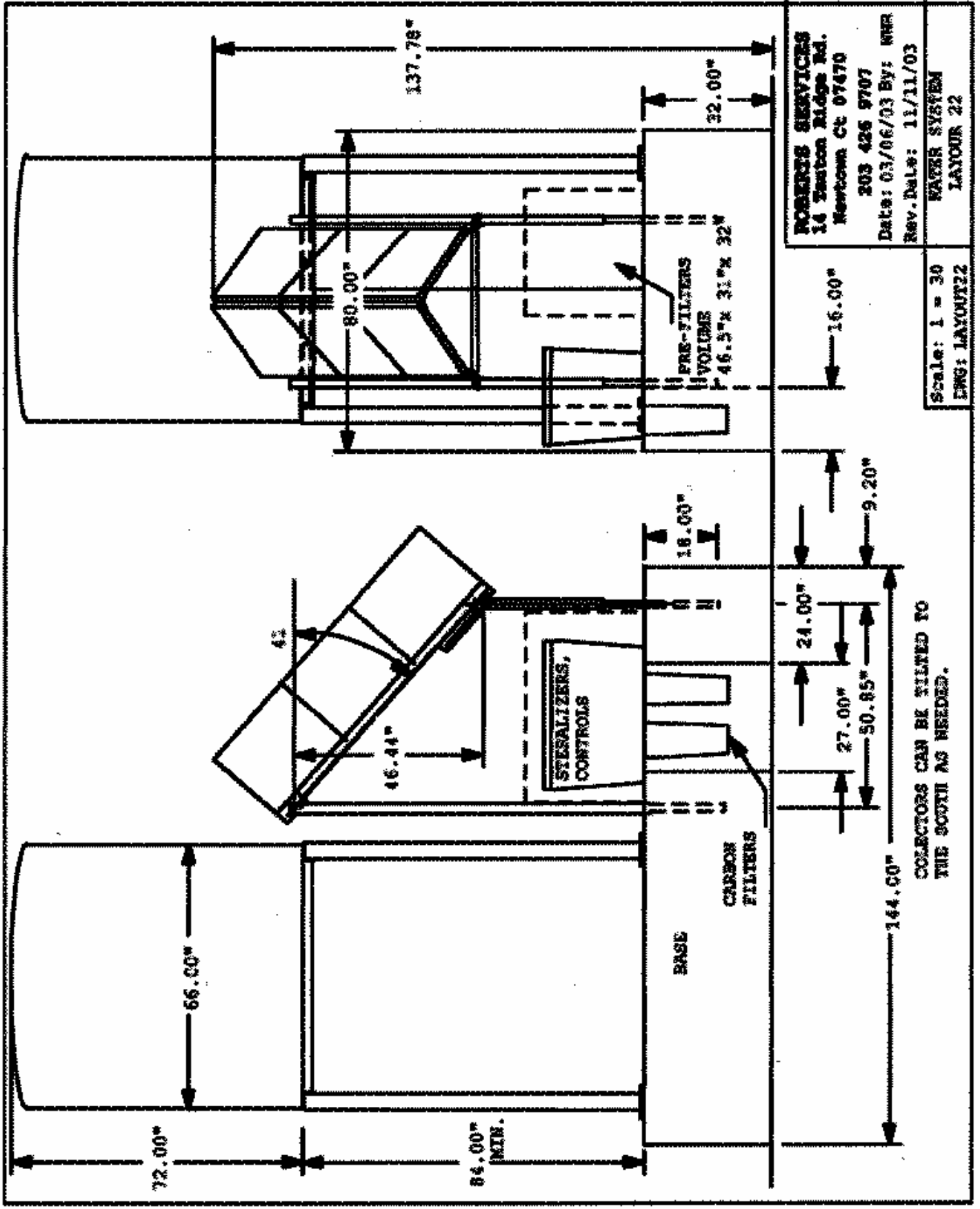

NORBERT SERVICES
 14 Sutton Ridge Rd.
 Newtown Ct 07470

203 426 9707
 Date: 03/06/03 By: NHR
 Rev. Date: 11/11/03

WATER SYSTEM
 LAYOUT 22

Scale: 1 = 30
 ENG: LAYOUT22

COLLECTORS CAN BE FILLED TO
 THE SOUTH AS NEEDED.

PURIFICATION FLOW SEQUENCE

- P PUMP
- PF1 PRE-FILTER #1
- SP STAND PIPE
- PF2 PRE-FILTER #2
- S1 & S2 STERILIZERS #1 & #2
- F1 CARBON FILTER #1
- F2 CARBON FILTER #2
- T TANK
- AF AIR BREATHING FILTER
- S3 & S4 STERILIZERS #3 & #4
- V9- V16 DISTRIBUTION VALVES

G1, G2, G3 PRESSURE GAGES
 V0 VALVE, TANK ISOLATION

NORMAL FLOW

VALVES OPEN: V0, V1, V2, V5
 VALVES CLOSED: V3, V4, V6, V7

BACK-WASH PRE-FILTER #1

VALVES OPEN: V3, V4
 VALVES CLOSED: V0, V1, V2, V5, V6, V7

BACK-WASH PRE-FILTER #2

VALVES OPEN: V3, V7
 VALVES CLOSED: V0, V1, V2, V4, V5, V6

FLUSH PRE-FILTER #1

VALVES OPEN: V1, V4
 VALVES CLOSED: V0, V2, V3, V5, V6, V7

FLUSH PRE-FILTER #2

VALVES OPEN: V2, V7
 VALVES CLOSED: V0, V1, V3, V4, V5, V6

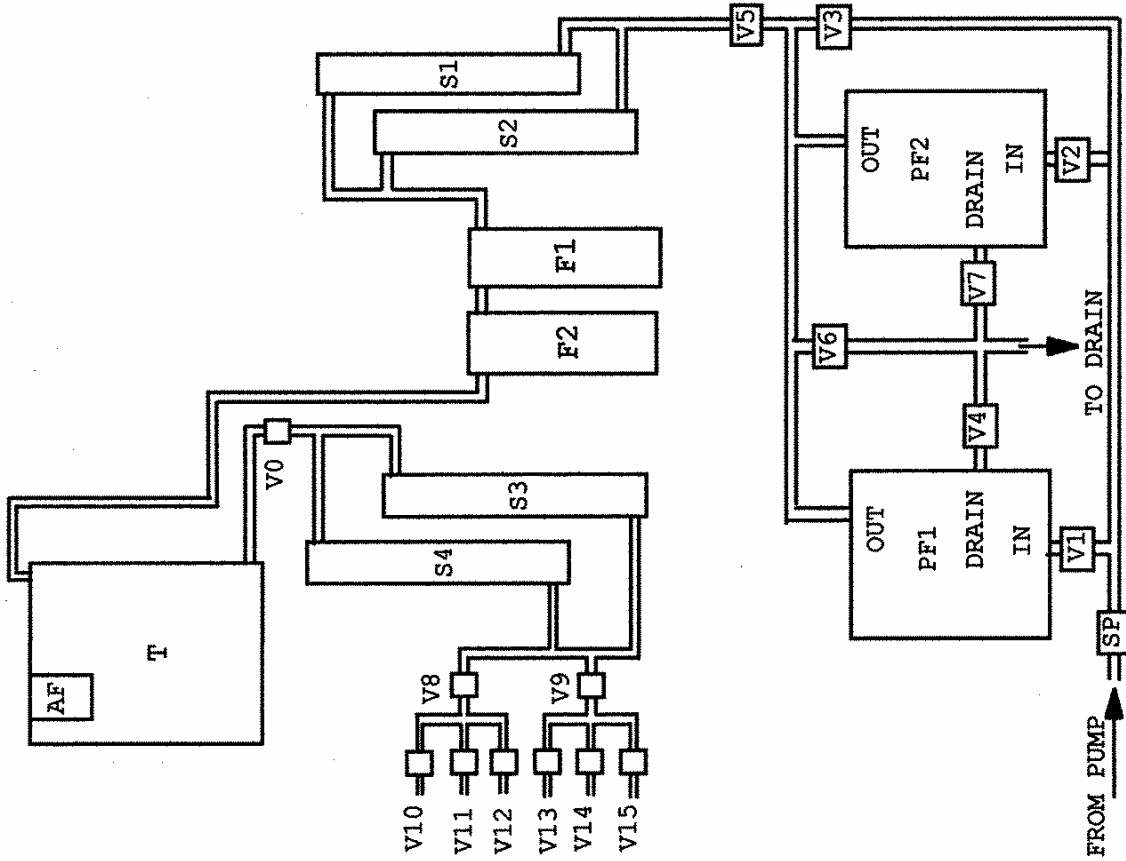

ROBERTS SERVICES
 14 Tauton Ridge Rd.
 Newtown Ct 07470
 203 426 9707
 Date: 08/01/03 BY WNR
 REV:

Scale: 1" = 1"
 DWG. SCHEM03

SCHEMATIC, #3
 WATER PURIFICATION